



CRAGHOPPERS

EXPERT

DISCOVER YOUR WORLD

SINCE 1965

AUTUMN/WINTER 2022



CRAGHOPPERS

Back in 1965 when Craghoppers hit upon the idea of turning a passion for travel into a bona fide business, the team felt like they were embarking on an exciting and at times perilous trip into the unknown. Looking back, their perseverance paid off and Craghoppers is now recognised as a global outdoor and adventure travel specialist.

The world may have moved on over the last 56 years but our mission today is the same as it was all those decades ago - to create comfortable and practical clothing ranges to help our customers stay on the trail as long as possible. And every year, we get that little bit better. By introducing new designs, using the latest technologies, keeping sustainability at the heart of everything we do and bringing that special spirit of innovation, our products are more comfortable, lighter, more waterproof, insulating and sun-protective than ever before.



CRAGHOPPERS

EXPERT

Taking these technologies and our sustainability ethos, we have applied them to our new Craghoppers Expert range to ensure that we offer the very best performance for all day wear at the workplace - wherever that may be.

A collection of clothing and accessories for professionals working in the outdoors.

SINCE 1965



WHO WE ARE

CRAGHOPPERS ARE WORKING TO
BECOME A GLOBAL LEADER FOR
ACCESSIBLE, INNOVATIVE AND
SUSTAINABLE CLOTHING FOR
THE OUTDOORS.





OUR EMBLEM

THE MOUFLON

The spirit of Craghoppers is embodied by the mouflon ram, one of the hardiest animals in the world, thriving in inhospitable mountain environments.

Born nomads, the mouflon rarely stays in one place long, constantly wandering and exploring new territories. This is brought to life with our mouflon logo.



THE HISTORY OF OUR BRAND

1965

Craghoppers
first Everest expedition

2002

Nosquito insect
clothing introduced
—
Launch of
Mail Order

1975

Designed weather wear
for **Chris Bonnington's**
successful ascent
of Everest

2003

Epic **water-re-**
fabrics & UPF
sun-protective
introduced
—
Launch of
craghoppers.
—
First Mail Order
wins at the **E**
Awards

1996

Launch of the iconic
Kiwi Trousers

2006

Merino clothing
introduced
—
Signed **Bear C**

1999

AquaDry waterproof
membrane fabric
introduced

2000

Awarded **Millennium**
Products Marque for
Creativity and Innovation
for Dynamic Balance
technology within our
rucksacks

ect-repellent
duced

2008

GORE-TEX® fabrics introduced
— Partnered with **Bear Grylls** to create a clothing range designed especially for him to wear in extreme conditions.

ssistant
e clothing

2010

ClimaPlus insulating technology introduced
— Launch official **Duke of Edinburgh Award** kit
— Nosquito insect repellent clothing re-named **NosiLife**

com
er catalogue
CMOD

2012

First US Office opens in Newmarket, New Hampshire

ng
Grylls

2013

SolarShield ZnO introduced
— Joined the **European Outdoor Conservation Association**

2014

Sponsor **Dian Fossey Gorilla Fund**
— Partnered with **English Heritage**

2015

Recycled Fleece introduced
— New partnerships with **National Geographic** in the USA and **Royal Geographic Society**

2016

NosiDefence & RFID Protection introduced
— Sponsor **London School of Hygiene & Tropical Medicine's** "Bug Off" campaign
— **20 years** of Kiwi Trousers

2017

Partnered with **Discovery Adventures**
— Sponsored the **Wanderlust Travel Guide Awards**

2018

Launch of the **Craghoppers Film Prize with Discover. film**
— Partnered with **Chester Zoo**

2019

OdourControl & PFC free DWR introduced
— **Win 2019 Fashion Apparel/Footwear Ecommerce Website of the Year Award**

2020

Luggage and footwear introduced

2021

Dynamic 12000 fabric technology introduced
Energy recirculating clothing
— **Nosi Botanical** Plant based insect repellent clothing treatment
— **ECOSHIELD** A naturally water-resistant coating inspired by nature.
— Relaunch of **Expert** range

MINDFULLY MADE

2020 and 2021 were milestone years in our Sustainability Journey. In 2020, we won Drapers Sustainable Fashion Brand of the Year and we were shortlisted for the Drapers Positive Change Award in 2021. These were proud moments for the teams and the brand. They acknowledged how committed we are to making sustainable products in a sustainable way. But we don't want to stop there. We want to make positive progress every year and bring our factories and suppliers along with us.

In 2022, we joined the Sustainable Apparel Coalition and will be working collaboratively with other likeminded companies, using the Higg Index to enable us to benchmark our current performance against the best sustainability initiatives around, helping us set targets for our continuous improvement.

ETHICALLY MADE



68,000 WORKERS IN FACTORIES
ARE COVERED BY THE ETI BASE CODE
INSPECTED IN **122** FACTORIES IN **9**
COUNTRIES

REACHED OVER **14,000** WORKERS
WITH H&S TRAINING WORKSHOP

CONSIDERATELY MADE

OUR WORLD MATTERS TO US & OUR FAMILIES. WE HAVE BEEN WORKING WITH THESE INCREDIBLE CONSERVATION PROGRAMMES FOR MANY YEARS. WE SUPPORT A NUMBER OF CONSERVATION PROJECTS ACROSS THE WORLD INCLUDING:



SUSTAINABLY MADE RECYCLED MATERIALS



64 MILLION PLASTIC BOTTLES
RECYCLED BY THE END OF **2021**

70% OF OUR PRODUCTS ARE MADE
FROM RECYCLED MATERIALS

OUR FABRICS USE YARNS
CERTIFIED IN ACCORDANCE WITH
THE GLOBAL RECYCLED STANDARD (GRS)



100% PFC FREE PRODUCTS

BETTER COTTON



NO TO DOWN

BLUESIGN SYSTEM
PARTNER



OUR WOOL PRODUCTS USE ETHICAL SOURCED WOOL FROM NON-MULESING FARMS, VERIFIED WITH CERTIFICATION FROM BRITISH WOOL AND AUSTRALIAN WOOL EXCHANGE.



MICROFIBRE
CONSORTIUM

HIGG INDEX



HONOURABLY MADE



WE ARE SO PROUD OF THE QUALITY OF OUR CLOTHING WE OFFER A GUARANTEE FOR LIFE

TIMPSON

Great Service by Great People
Est. 1903

WE WORK WITH TIMPSON TO OFFER OUR CONSUMERS A FREE REPAIR SERVICE, THEREFORE EXTENDING THE LIFE OF THE PRODUCTS



SELL OUR TERMINAL DONATED STOCK, PROFITS HELP TO PROVIDE ESSENTIAL EQUIPMENT FOR DISABLED CHILDREN, MEDICAL RESEARCH INTO BIRTH DEFECTS AND HELP FUND CAMPAIGNS AT LOCAL AND NATIONAL GOVERNMENT LEVEL

TRANSPARENTLY MADE



EMPOWERING FEMALE WORKERS IN BANGLADESH ON HEALTH, HYGIENE, NUTRITION AND FINANCE.

9 FACTORIES AND **15,500 WORKERS**

SAVAR PRIMARY SCHOOL, BANGLADESH

THE SCHOOL OFFERS LIFE-CHANGING EDUCATION FOR CHILDREN IN A SAFE AND EXCITING ENVIRONMENT FOR THEM TO LEARN AND GROW. WE HAVE POSITIVELY IMPACTED MORE THAN

3,300 FAMILIES TO DATE



REWARDING SHORT FILMMAKERS FROM AROUND THE WORLD

IN PARTNERSHIP WITH

discover.film 

CAREFULLY MADE



ENERGY EFFICIENCY

FROM APRIL-DECEMBER 2021, CO2 EMISSIONS AT HQ WERE REDUCED BY 466 TONNES THROUGH SOLAR PANELS - THE EQUIVALENT OF 1275 TREES

MEMBERS OF UN CLIMATE CHANGE GROUP AND PRIMARY MEMBERS OF SMART FREIGHT

SIGNATORIES TO THE UNFCCC FASHION FOR GLOBAL CLIMATE ACTION

RECYCLE



WE USE SUGARCANE PAPER FOR OUR OUTER SWING TICKETS - A HIGHLY RENEWABLE SOURCE, COMPOSTABLE AND RECYCLABLE

OUR INNER TICKETS ARE MADE FROM RECYCLED PAPER AND THE ATTACHMENT STRINGS FROM RECYCLED POLYESTER

ALL BRAND, TECH AND NON TECH SWING TICKETS HAVE BEEN REDUCED IN SIZE, WITH A PAPER SAVING OF 4.36KM² - LARGER THAN THE SURFACE AREA OF DERWENT RESERVOIR.

OUR PLASTIC BAGS ARE MADE FROM 50% RECYCLED MATERIAL & ARE FULLY RECYCLABLE

SINCE 2016, THERE HAS BEEN ZERO LANDFILL FROM ANY WASTE FROM OUR UK FACILITIES

OPERATIONS



IN 2021, 18% OF OUR CONTAINERS WERE TRANSPORTED ON BIOFUEL VESSELS

COMPLIANCE WITH THE CONTROL OF SUBSTANCES HAZARDOUS TO HEALTH REGULATIONS 2002 (COSHH)



ENGLISH HERITAGE

WE HAVE BEEN WORKING WITH ENGLISH HERITAGE FOR OVER A YEAR NOW AS PART OF A 3 YEAR PARTNERSHIP.

We have provided the charity with £1 million worth of outerwear comprising waterproof jackets, softshell and fleece to keep its 3,700 site-based staff and volunteers warm and dry across 400 plus iconic historical sites across England.



DANIEL HALE
HEAD GARDENER AT BRODSWORTH HALL AND GARDENS, SOUTH YORKSHIRE

"I oversee the maintenance and restoration of the beautiful Victorian garden, bringing history to life for our visitors."

Daniel Hale



EDWARD WOOLARD
AREA CATERING MANAGER ACROSS THE NORTH

"I work across the North English Heritage sites, trying lots of delicious local foods and planning new and exciting things for our menus."

Edward Woolard

PARTNERSHIPS





RACHEL MORRISON

AUDIENCE DEVELOPMENT MANAGER FOR MARBLE HILL, TWICKENHAM

"I am currently working on a £6 million revival project that will open the house more often for free; revive the landscape and improve the facilities across the park - from the play area to the sports pitches."

Rachel Morrison



KELLY FOWLER

SENIOR GARDENER AT AUDLEY END HOUSE AND GARDENS, ESSEX

"I work in the organic walled kitchen garden, tending to the care of historic fruit trees, delicious vegetables and seasonal floral displays - where every day is truly different."

Kelly Fowler





**WE HAVE BEEN WORKING
WITH THE DIAN FOSSEY
GORILLA FUND INTERNATIONAL
FOR OVER 8 YEARS.**

We provide the trackers and rangers with clothing that will protect them from the elements so that they can research and monitor the gorillas in the wilds of the Congo and Rwanda. They require kit which is hardwearing and will keep them warm and dry in the mountain forests.

The conservation work carried out at the Dian Fossey Gorilla Fund focuses on four main areas: the daily protection of the gorillas, scientific research on gorillas and the eco systems, education and helping the local communities.

PARTNERSHIPS





OUR PARTNERS

It's the company you keep that makes you strong. We work with some well-respected, recognisable organisations that share our values and help us realise that this is more than just a business, it's a passion.



Saving the Survivors



Galapagos Conservation Trust



Duke of Edinburgh



English Heritage



Dian Fossey Gorilla Fund



Walking With The Wounded



Discover Film



WeTwo

AMBASSADORS

We work with some fantastic Ambassadors who through their amazing challenges or their everyday work, test our clothing to its limits and give us valuable feedback. We have photographers, filmmakers, conservationists and adventurers. They travel across many environments and a range of climates, inspiring us all to join their adventures.



KEVIN RICHARDSON WILDLIFE CONSERVATIONIST AND FILMMAKER, SA

Kevin the 'Lion Whisperer's' mission is to highlight the plight of lions in captivity and in the wild.

Kevin Richardson



CHAZ POWELL EXPEDITION LEADER & SURVIVAL GUIDE

After exploring and hiking the globe for the past 17 years, Chaz now lives his life as an Expedition Leader and Survival Guide in the North of Scotland, living sustainably.

Chaz Powell



SABAH AHMED OUTDOOR ADVENTURER & FOUNDER OF SUMMIT SPECIAL

Sabah works to empower and enable women to experience the outdoors. A trained physiotherapist and founder of Summit Special a group encouraging minority groups in outdoor adventures.

Sabah Ahmed



CRAIG GRIMES MANAGING DIRECTOR OF EXPERIENCE COMMUNITY CIC, UK

Craig has built a community of disabled people who, with families and friends, can experience the great outdoors together.

Craig Grimes



JACK FLECKNEY ADVENTURER

Jack has been a rugby player and Royal Marine Commando and he loves a challenge. In 2022, he will be travelling 2000km across Africa, completing challenges and working on community projects along the way.

Jack Fleckney

TECHNOLOGIES

At Craghoppers we pride ourselves on producing innovative and high performance fabrics and technologies. We are proud to say that the full Craghoppers Expert collection has been made with fabrics incorporating recycled materials.



AQUADRY

Guaranteed waterproof and breathable protection

Guaranteed waterproof and breathable fabric. A combination of our waterproof and breathable coating and our technical outer fabrics delivers guaranteed levels of protection and comfort. The outer face is treated with EcoShield plant based DWR (Durable Water repellent) finish to help keep the outer fabric drier for longer.

The final product provides guaranteed breathability and all-round waterproof performance.



ECOSHIELD

Naturally water resistant

A naturally water-resistant coating, inspired by nature. 63% renewably sourced from a variety of plant-based sources. EcoShield allows fabrics to be quick drying and also repels water based stains.



THERMO PRO

Tough, agile and protective

A new insulating technology that provides a viable synthetic alternative to natural down. The innovative ThermoPro fill uses specially constructed fibres to simulate down construction, delivering comparable heat retention properties. Light, high loft and quick-drying for effortless efficiency in cold and wet conditions.



SOLAR SHIELD

UPF40+ sun protective clothing

SolarShield is Craghoppers' range of sun-protective fabric tested for UV-protection UPF40+.

Sun-protection is given by a combination of 3 things, the density of the fabric construction, the type of yarns used and its colour.



NOSI DEFENCE

An effective barrier to biting insects

NosiDefence provides a robust barrier of specially constructed fibres which are too tough for insects like mosquitoes to penetrate. NosiDefence fabric will help to defend your skin from insect bites allowing you to enjoy your work carefree.



World leading waterproof and breathable fabrics for all weather conditions.

Craghoppers together with Gore, create world leading waterproof and breathable jackets for all weather conditions. Adventurers world-wide have been putting GORE-TEX Products through their paces for years and it still comes out on top as the finest waterproof and breathable fabric there is. Now with a PFCec free durable water repellent finish.

EXPERT

PROTECTION AGAINST RAIN

Waterproof and breathable.
Craghoppers Expert garments
conform to class 3:1.



EN 343

The European Standard 'EN 343:2019 Protection against rain' distinguishes between four classes of a garments performance, based on separate water-proofness and breathability capabilities.

WATERPROOFNESS

Waterproofness of the material is measured by testing the level of resistance to water penetration (Wp). Hydrostatic pressure is measured in a column of water (in Pascals) until water penetrates the fabric.

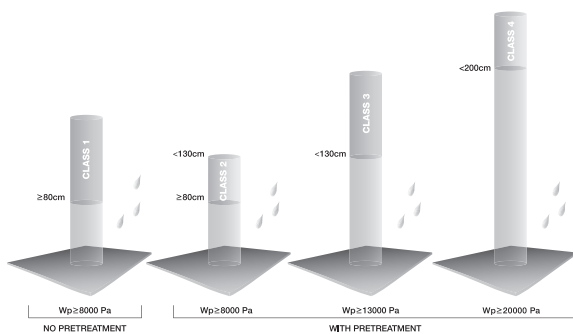

BREATHABILITY

The water vapour permeability or breathability of a garment is tested by measuring its resistance to water vapour. The lower the Ret value, the higher the breathability of the material.

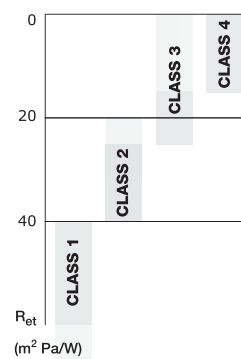

FEATURES

Craghoppers is renowned for its features and benefits, we pay great care and attention to ensure each garment has the added features and functionality that it might need.

These features include:



RFID BLOCKING POCKETS - Our special lining fabric helps prevent accidental use or deliberate mis-use of credit cards and passports by blocking radio signals from activating the chip.



ODOUR CONTROL PATCHES - Our OdourControl technology uses innovative fabric patches in key areas to capture and absorb odour molecules to help you stay fresher for longer.



HOT POCKETS - A thermal fabric layer in the lining that reflects body heat for when the temperature drops.



HEEL TAPE - For added durability in a high wear area.



CRAGHOPPERS

— — — — —
EXPERT

BRANDING

The Craghoppers Expert range has been specially developed for corporate and workwear use. Giving companies and customers the opportunity to add their branding to the garments. The only external branding is a tonal mouflon and Craghoppers logo which features in discreet places on the garments.

For waterproof/lined garments we have reviewed the access points for branding, they have zipped access which has been moved to below the inner drip strip to allow easier access to more of the garment.

GUARANTEED FOR LIFE



Making products that last is a key ingredient to sustainability. We are so proud of the quality of our clothing that we offer a Guarantee for Life.

All you need to do is register your clothing with us, keep your proof of purchase and if we are unable to repair it, it will be replaced for the same or like for like item, organised by our dedicated Customer Service team.

Due to the nature of usage, our luggage, footwear and walking pole collections are covered by the following warranties:

Luggage: 5 Years from date of purchase

Footwear and walking poles: 2 years from date of purchase

All would require proof of purchase and an assessment from our dedicated team.

PRODUCT REPAIR

We have joined forces with the Timpson Group - the UK's largest branch network of Repairs and Alterations, Dry Cleaning and Laundry to offer a free repair service for our customers.

TIMPSON

Great Service by Great People
Est. 1903



Expert Kiwi Pro Stretch 3in1 Jacket CEP003



EN 343



3G3
Dark Navy



800
Black



EXPERT KIWI PRO STRETCH 3IN1 JACKET

Fabric Description:

EN343-3 Bluesign-approved AquaDry Membrane polyester stretch with EcoShield DWR, polyester stretch mesh & recycled polyester taffeta lining outer. Recycled polyester elastane softshell with EcoShield DWR finish & striped microfleece back inner. Recycled zip tapes to all but outer jacket chest pocket.

Fabric Composition:

Outer: 100% polyester / inner: 96% polyester, 4% elastane

Sizes:

XS - 3XL

Fit:

Active

Weight:

695g

Branding Options:

Embroidery, Vinyl, Screen, Transfer

33" length • 6 pockets • 2 bellowed stud fastening lower with fused flaps and zipped side handwarmers • 1 waterproof zipped chest • 1 zipped inner map • Stud fastening stormflap with inner zip guard • Inner drawcord hem adjusters • Grown on hood with toggle adjusters to front & adjuster to back • Fused self fabric cuff adjusters • Inner softshell with 2 zipped pockets & adjustable hem • Reflective detail • Inner zip access for logos • Approximately 550g of recycled material went into making this product.



Expert Thermic Insulated Jacket CEP001



EN 343



800
Black



3G3
Dark Navy



J8V
Carbon Grey /
Black
New



Fabric Description:

EN343-1 Bluesign-approved AquaDry Membrane recycled polyester with EcoShield DWR, recycled polyester lux lining & recycled polyester hollowfibre fill. Recycled zip tapes to inner chest pocket and back zip for logo access.

Fabric Composition:

100% polyester

Sizes:

XS - 3XL

Fit:

Active

Weight:

870g

Branding Options:

Embroidery, Vinyl, Screen, Transfer

30.5" length • 4 pockets • 2 waterproof zipped lower • 1 zipped inner map • 1 mobile phone • Waterproof centre front zip with inner zip guard • Inner drawcord hem adjusters • Grown on hood with toggle adjusters to front & adjuster to back • Self fabric cuff adjusters • Reflective detail • Inner zip access for logos • Warmth rating 2 • Approximately 75 bottles were recycled to make this product.



Expert Packable Jacket CEW011



EN 343



3G3
Dark Navy
New



800
Black
New



JT5
Poseidon Blue
New



NEW - EXPERT PACKABLE JACKET

Fabric Description:

EN343-3 Bluesign-approved AquaDry Membrane polyester 2.5L with EcoShield DWR, recycled polyester trim & recycled zip tapes.

Fabric Composition:

100% polyester

Sizes:

XS - 3XL

Fit:

Active

Weight:

90g/m²

Branding Options:

Embroidery, Vinyl, Screen, Transfer

30" length • 2 pockets • 2 welted zipped lower • Full length zip with inner zip & chin guard • Inner drawcord hem adjusters • Grown on hood with toggle adjusters to front & adjuster to back • Fused self fabric cuff adjusters • Reflective detail • Stuff sack • 90g/m² • Approximately 19 bottles were recycled to make this product.



Expert Expolite Thermal Jacket CEN001



3G3
Dark Navy



800
Black



W35
Carbon Grey



EXPERT EXPOLITE THERMAL JACKET

Fabric Description:

Recycled polyester mini ripstop with EcoShield DWR finish outer and lining, ThermoPro recycled polyester fill & recycled zip tapes.

Fabric Composition:

100% polyester

Sizes:

XS - 3XL

Fit:

Tailored

Weight:

360g

Branding Options:

Embroidery, Vinyl, Screen, Transfer

27" length • 4 pockets • 2 welted zipped lower • 1 concealed zipped inner • 1 passport RFID • Full length zip with inner zip & chin guard • Inner drawcord hem adjusters • Elasticated bound cuffs • RHS outer pocket doubles as stow pocket • Warmth rating 2 • Fill: g/m2 • Approximately 30 bottles were recycled to make this product.



Expert Gore-Tex Jacket CEW006



800
Black
New



NEW - EXPERT GORE-TEX JACKET

Fabric Description:

Bluesign-approved 2 layer recycled polyester stretch Gore-Tex performance shell with polyester stretch mesh & recycled polyester tafetta lining. Recycled zip tapes to all but outer lower pockets.

Fabric Composition:

Outer: 100% polyester with GORE-TEX Membrane / Lining: 100% polyester

Sizes:

XS - 3XL

Fit:

Active

Weight:

670g

Branding Options:

Embroidery, Vinyl, Screen, Transfer

32" length • 6 pockets • 2 bellowed stud fastening lower with zipped side handwarmers • 1 zipped inner map • 1 mobile phone • Stud fastening stormflap with inner zip guard • Inner drawcord hem adjusters • Grown on hood with toggle adjusters to front & back • Self fabric cuff adjusters • Approximately 40 bottles were recycled to make this product.



Expert Gore-Tex Trouser CEW005



800
Black
New

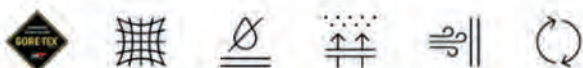

NEW - EXPERT GORE-TEX TROUSER

Fabric Description:

Bluesign-approved 2 layer recycled polyester stretch Gore-Tex performance shell with polyester stretch mesh & recycled polyester tafetta lining. Recycled zip tapes to all but outer lower pockets.

Fabric Composition:

Outer: 100% polyester with GORE-TEX Membrane / Lining: 100% polyester

Sizes:

S/R/L 30 - 42

Fit:

Active

Branding Options:

Embroidery, Vinyl, Screen, Transfer

Approximately 20 bottles were recycled to make this product.



Expert Padded Jacket CEN003



3G3
Dark Navy
New



800
Black
New



NEW - EXPERT PADDED JACKET

Fabric Description:

Polyamide ripstop with EcoShield DWR finish, recycled polyester lining, ThermoPro recycled polyester fill & recycled zip tapes.

Fabric Composition:

Outer: 100% polyamide. Lining & fill: 100% polyester

Sizes:

XS - 3XL

Fit:

Relaxed

Weight:

60g/m²

Branding Options:

Embroidery, Vinyl, Screen, Transfer

32" length • 4 pockets • 2 zipped lower • 1 concealed zipped inner • 1 passport RFID • Full length zip with stud fastening placket & inner zip guard • Inner drawcord hem adjusters • Grown on hood with toggle adjuster to back for full crown adjustment • Ribbed inner cuffs • Warmth rating 3 • 60g/m² • Approximately 500g of recycled material went into making this product.



Expert Kiwi Pro Stretch Long Jacket CEW001



EN 343



J8V
Carbon Grey /
Black
New



800
Black



3G3
Dark Navy



Fabric Description:

EN343-3 Bluesign-approved AquaDry Membrane polyester stretch with EcoShield DWR, polyester stretch mesh & recycled polyester taffeta lining. Recycled zip tapes to all but outer chest pocket.

Fabric Composition:

100% polyester

Sizes:

XS - 3XL

Fit:

Active

Weight:

720g

Branding Options:

Embroidery, Vinyl, Screen, Transfer

33" length • 6 pockets • 2 bellowed stud fastening lower with fused flaps and zipped side handwarmers • 1 waterproof zipped chest • 1 zipped inner map • Stud fastening stormflap with inner zip guard • Inner drawcord hem adjusters • Grown on hood with toggle adjusters to front & adjuster to back • Fused self fabric cuff adjusters • Reflective detail • Inner zip access for logos • Approximately 130g of recycled material went into making this product.



Expert Active Jacket CEW004



R5P
Dark Cedar
Green / Black
New



R4V
Poseidon Blue /
Dark Navy
New



J8V
Carbon Grey /
Black
New



NEW - EXPERT ACTIVE JACKET

Fabric Description:

EN343-3 Bluesign-approved AquaDry Membrane polyester stretch with EcoShield DWR, polyester stretch mesh & recycled polyester taffeta lining. Recycled zip tapes to inner zips.

Fabric Composition:

100% polyester

Sizes:

XS - 3XL

Fit:

Active

Weight:

555g

Branding Options:

Embroidery, Vinyl, Screen, Transfer

30" length • 3 pockets • 2 waterproof zipped lower • 1 zipped inner map • Full length waterproof two way centre front zip with inner zip guard • Inner drawcord hem adjusters • Grown on hood with toggle adjusters to front & back • Fused self fabric cuff adjusters • Reflective detail • Inner zip access for logos • Approximately 120g of recycled material went into making this product.



Expert Active Hooded Softshell Jacket CEL005



800
Black
New



R4V
Poseidon Blue /
Dark Navy
New



J8V
Carbon Grey /
Black
New



NEW - EXPERT ACTIVE HOODED SOFTSHELL JACKET

Fabric Description:	Recycled polyester elastane softshell with honeycomb microfleece back, AquaDry Membrane, EcoShield DWR finish & recycled zip tapes.
Fabric Composition:	94% polyester, 6% elastane
Sizes:	XS - 3XL
Fit:	Relaxed
Weight:	575g
Branding Options:	Embroidery, Vinyl, Screen, Transfer

30" length • 2 pockets • 2 zipped lower • Full length zip with inner zip & chin guard • Inner drawcord hem adjusters • Grown on hood with toggle adjusters to front & adjuster to back • Self fabric cuff adjusters • Approximately 50 bottles were recycled to make this product.

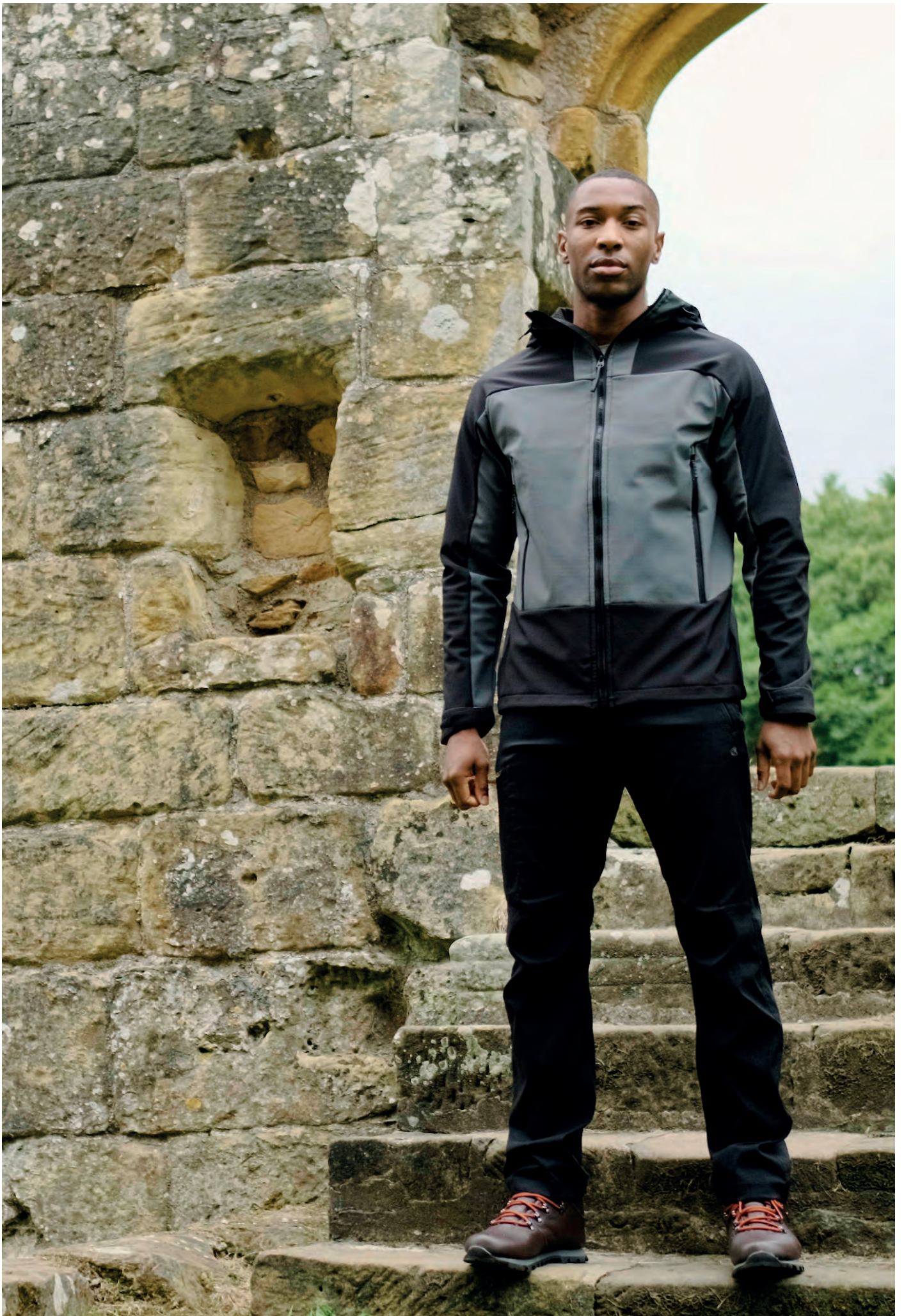

Expert Basecamp Softshell Jacket CEL003



3G3
Dark Navy



JT5
Poseidon Blue
New



800
Black



1TJ
Dark Cedar
Green
New



W35
Carbon Grey



Fabric Description:

Recycled polyester elastane softshell with EcoShield DWR finish, striped microfleece back & recycled zip tapes.

Fabric Composition:

94% polyester, 6% elastane

Sizes:

S - 3XL

Fit:

Relaxed

Weight:

575g

Branding Options:

Embroidery, Vinyl, Screen, Transfer

28.5" length • 3 pockets • 2 zipped lower • 1 welted zipped chest • Full length zip with inner zip & chin guard • Inner drawcord hem adjusters • Elasticated bound cuffs • Approximately 45 bottles were recycled to make this product.



Expert Womens Basecamp Softshell Jacket CEL004



800
Black



3G3
Dark Navy



1TJ
Dark Cedar
Green
New



JT5
Poseidon Blue
New



W35
Carbon Grey



Fabric Description:

Recycled polyester elastane softshell with EcoShield DWR finish, striped microfleece back & recycled zip tapes.

Fabric Composition:

94% polyester, 6% elastane

Sizes:

8 - 20

Fit:

Tailored

Weight:

500g

Branding Options:

Embroidery, Vinyl, Screen, Transfer

27" length • 3 pockets • 2 zipped lower • 1 welted zipped chest • Full length zip with inner zip & chin guard • Inner drawcord hem adjusters • Elasticated bound cuffs • Approximately 45 bottles were recycled to make this product.



Expert Active Half Zip Fleece CEA004



D30
Poseidon Blue
Marl
New



F18
Carbon Grey
Marl
New



Z8A
Potters Clay Marl
New



NEW - EXPERT ACTIVE HALF ZIP FLEECE

Fabric Description:

Recycled textured polyester fleece with 100% recycled polyester microfleece inner collar & recycled zip tapes.

Fabric Composition:

100% polyester

Sizes:

XS - 3XL

Fit:

Active

Weight:

366g

Branding Options:

Embroidery

28" length • 1 pocket • 1 zipped chest • Half-zip • Elasticated bound hem • Elasticated bound cuffs • Elasticated bound collar • Approximately 30 bottles were recycled to make this product.



Expert Corey 200 Fleece Half Zip CEA003



800
Black



W35
Carbon Grey
New



3G3
Dark Navy



1TJ
Dark Cedar
Green
New



Fabric Description:

100% recycled polyester microfleece & recycled zip tapes.

Fabric Composition:

100% polyester

Sizes:

XS - 3XL

Fit:

Active

Weight:

300g

Branding Options:

Embroidery

28" length • Half-zip • Approximately 40 bottles were recycled to make this product.



Expert Corey 200 Fleece Jacket CEA001



1TJ
Dark Cedar
Green
New



W35
Carbon Grey



3G3
Dark Navy



JT5
Poseidon Blue
New



W65
Potters Clay
New



800
Black



Fabric Description:

100% recycled polyester microfleece & recycled zip tapes.

Fabric Composition:

100% polyester

Sizes:

S - 3XL

Fit:

Active

Weight:

375g

Branding Options:

Embroidery

28" length • 3 pockets • 2 welted zipped lower • 1 zipped chest • Full length zip • Approximately 40 bottles were recycled to make this product.



Expert Womens Miska 200 Fleece Jacket CEA002



800
Black



JT5
Poseidon Blue
New



3G3
Dark Navy



1TJ
Dark Cedar
Green
New



W35
Carbon Grey



W65
Potters Clay
New



Fabric Description:

100% recycled polyester microfleece & recycled zip tapes.

Fabric Composition:

100% polyester

Sizes:

8 - 20

Fit:

Active

Weight:

310g

Branding Options:

Embroidery

27" length • 3 pockets • 2 welted zipped lower • 1 zipped chest • Full length zip • Approximately 35 bottles were recycled to make this product.



Expert Padded Vest CEB008



3G3
Dark Navy
New



800
Black
New



NEW - EXPERT PADDED VEST

Fabric Description:

Polyamide ripstop with EcoShield DWR finish, recycled polyester lining, ThermoPro recycled polyester fill & recycled zip tapes.

Fabric Composition:

Outer: 100% polyamide. Lining & fill: 100% polyester

Sizes:

XS - 3XL

Fit:

Relaxed

Weight:

60g/m²

Branding Options:

Embroidery, Vinyl, Screen, Transfer

28" length • 4 pockets • 2 zipped lower • 1 concealed zipped inner • 1 passport RFID • Full length zip with inner zip guard • Inner drawcord hem adjusters • Warmth rating 3 • 60g/m² • Approximately 410g of recycled material went into making this product.



Expert Expolite Thermal Vest CEB001



800
Black



3G3
Dark Navy



EXPERT EXPOLITE THERMAL VEST

Fabric Description: Recycled polyester mini ripstop with EcoShield DWR finish outer and lining, ThermoPro recycled polyester fill & recycled zip tapes.

Fabric Composition: 100% polyester

Sizes: XS - 3XL

Fit: Tailored

Weight: 255g

Branding Options: Embroidery, Vinyl, Screen, Transfer

27" length • 4 pockets • 2 welted zipped lower • 1 concealed zipped inner • 1 passport RFID • Full length zip with inner zip & chin guard • Inner drawcord hem adjusters • RHS outer pocket doubles as stow pocket • Warmth rating 2 • Fill: g/m2 • Approximately 18 bottles were recycled to make this product.



Expert Basecamp Softshell Vest CEB003



3G3
Dark Navy



W35
Carbon Grey
New



800
Black



Fabric Description:

Recycled polyester elastane softshell with EcoShield DWR finish, striped microfleece back & recycled zip tapes.

Fabric Composition:

94% polyester, 6% elastane

Sizes:

XS - 3XL

Fit:

Relaxed

Weight:

390g

Branding Options:

Embroidery, Vinyl, Screen, Transfer

27.5" length • 3 pockets • 2 zipped lower • 1 welted zipped chest • Full length zip with inner zip & chin guard • Elasticated bound armholes • Approximately 30 bottles were recycled to make this product.



Expert Corey Fleece Vest CEB007



800
Black



3G3
Dark Navy



EXPERT COREY FLEECE VEST

Fabric Description:	100% recycled polyester microfleece & recycled zip tapes.
Fabric Composition:	100% polyester
Sizes:	XS - 3XL
Fit:	Active
Weight:	205g/m ²
Branding Options:	Embroidery

27.5" length • 2 pockets • 2 welted zipped lower • Full length zip • 205g/m² • Approximately 30 bottles were recycled to make this product.



Expert Kiwi Long Sleeved Shirt CES001



WAI
Dark Cedar
Green



800
Black



62A
Pebble



W35
Carbon Grey



EXPERT KIWI LONG SLEEVED SHIRT

Fabric Description: Recycled polyester & BCI cotton shirting with recycled zip tapes.

Fabric Composition: 65% polyester, 35% cotton

Sizes: S - 3XL

Fit: Relaxed

Weight: 255g

Branding Options: Embroidery, Vinyl, Screen, Transfer

31" length • 3 pockets • including 1 hidden zipped security • UPF 40+ sun-protection • Approximately 19 bottles were recycled to make this product.



Expert Womens Kiwi Long Sleeved Shirt CES002



800
Black



62A
Pebble



WAI
Dark Cedar
Green



W35
Carbon Grey



EXPERT WOMENS KIWI LONG SLEEVED SHIRT

Fabric Description: Recycled polyester & BCI cotton shirting with recycled zip tapes.

Fabric Composition: Main: 65% polyester, 35% cotton / Trim: 100% polyester

Sizes: 8 - 20

Fit: Tailored

Weight: 185g

Branding Options: Embroidery, Vinyl, Screen, Transfer

26" length • 2 pockets • including 1 hidden zipped security • UPF 40+ sun-protection • Approximately 15 bottles were recycled to make this product.



Expert Kiwi Short Sleeved Shirt CES003



800
Black



62A
Pebble



EXPERT KIWI SHORT SLEEVED SHIRT

Fabric Description: Recycled polyester & BCI cotton shirting with recycled zip tapes.

Fabric Composition: 65% polyester, 35% cotton

Sizes: S - 3XL

Fit: Relaxed

Weight: 255g

Branding Options: Embroidery, Vinyl, Screen, Transfer

31" length • 3 pockets • including 1 hidden zipped security • Approximately 16 bottles were recycled to make this product.



Expert Womens Kiwi Short Sleeved Shirt CES004



800
Black



62A
Pebble



EXPERT WOMENS KIWI SHORT SLEEVED SHIRT

Fabric Description: Recycled polyester & BCI cotton shirting with recycled zip tapes.

Fabric Composition: Main: 65% polyester, 35% cotton / Trim: 100% polyester

Sizes: 8 - 20

Fit: Tailored

Weight: 185g

Branding Options: Embroidery, Vinyl, Screen, Transfer

26" length • 2 pockets • including 1 hidden zipped security • Approximately 12 bottles were recycled to make this product.



Expert Kiwi Tailored Trousers CEJ001



62A
Pebble



W35
Carbon Grey



800
Black



3G3
Dark Navy



EXPERT KIWI TAILORED TROUSERS

Fabric Description:	Peached recycled polyester & BCI cotton with EcoShield DWR finish & recycled zip tapes.
Fabric Composition:	65% polyester, 35% cotton
Sizes:	S/R/L 30 - 42
Fit:	Tailored
Weight:	465g
Branding Options:	Embroidery, Vinyl, Screen, Transfer

9 pockets • including 5 zipped & 1 mobile phone • Part elasticated waist at sides with belt included • UPF 40+ sun-protection • Approximately 23 bottles were recycled to make this product.



Expert Womens Kiwi Trousers CEJ002



3G3
Dark Navy



W35
Carbon Grey



800
Black



62A
Pebble



EXPERT WOMENS KIWII TROUSERS

Fabric Description: Peached recycled polyester & BCI cotton with EcoShield DWR finish & recycled zip tapes.

Fabric Composition: 65% polyester, 35% cotton

Sizes: S/R/L 8 - 20

Fit: Relaxed

Weight: 325g

Branding Options: Embroidery, Vinyl, Screen, Transfer

6 pockets • including 3 zipped & 1 mobile phone • Part elasticated waist at back • UPF 40+ sun-protection
• Approximately 22 bottles were recycled to make this product.





Expert Womens Kiwi Convertible Trousers CEJ006



3G3
Dark Navy



800
Black



EXPERT WOMENS KIWII CONVERTIBLE TROUSERS

Fabric Description: Peached recycled polyester & BCI cotton with EcoShield DWR finish & recycled zip tapes.

Fabric Composition: 65% polyester, 35% cotton

Sizes: S/R/L 8 - 20

Fit: Relaxed

Weight: 325g

Branding Options: Embroidery, Vinyl, Screen, Transfer

6 pockets • including 3 zipped & 1 mobile phone • Part elasticated waist at back • Approximately 22 bottles were recycled to make this product.

UK / EU Sizes

	8	10	12	14	16	18	20
S	•	•	•	•	•	•	•
R	•	•	•	•	•	•	•
L	•	•	•	•	•	•	•



Expert Kiwi Waterproof Thermo Trouser CEW009



800
Black
New



3G3
Dark Navy
New



NEW - EXPERT KIWI WATERPROOF THERMO TROUSER

Fabric Description:	Bluesign-approved AquaDry Membrane recycled polyester with brushed polyester lining & recycled zip tapes.
Fabric Composition:	100% polyester
Sizes:	30 - 42
Fit:	Active
Weight:	170g/m ²
Branding Options:	Embroidery, Vinyl, Screen, Transfer

3 pockets • all zipped • Part elasticated waist at sides • Hook & loop fastening hem adjusters
Approximately 65 bottles were recycled to make this product.



Expert Kiwi Long Short CEJ009



3G3
Dark Navy
New



800
Black
New



62A
Pebble
New



NEW - EXPERT KIWI LONG SHORT

Fabric Description:

Peached recycled polyester & BCI cotton with EcoShield DWR finish & recycled zip tapes.

Fabric Composition:

65% polyester, 35% cotton

Sizes:

30 - 42

Fit:

Relaxed

Weight:

335g

Branding Options:

Embroidery, Vinyl, Screen, Transfer

12" length short • 9 pockets • including 5 zipped & 1 mobile phone • Part elasticated waist at sides • Approximately 18 bottles were recycled to make this product.





Expert Kiwi Pro Stretch Trousers CEJ003



800
Black



3G3
Dark Navy



EXPERT KIWI PRO STRETCH TROUSERS

Fabric Description:

Stretch recycled polyamide elastane with EcoShield DWR finish & recycled zip tapes.

Fabric Composition:

Main: 96% polyamide, 4% elastane / Pocket bags: 65% polyester, 35% cotton

Sizes:

S/R/L 30 - 42

Fit:

Active

Weight:

340g

Branding Options:

Embroidery, Vinyl, Screen, Transfer

4 pockets • all zipped • Part elasticated waist at sides • UPF 40+ sun-protection • Approximately 280g of recycled material went into making this product.



Expert Womens Kiwi Pro Stretch Trousers CEJ004



3G3
Dark Navy



800
Black



EXPERT WOMENS KIWI PRO STRETCH TROUSERS

Fabric Description:

Stretch recycled polyamide elastane with EcoShield DWR finish & recycled zip tapes.

Fabric Composition:

Main: 96% polyamide, 4% elastane / Pocket bags: 65% polyester, 35% cotton

Sizes:

S/R/L 8 - 20

Fit:

Active

Weight:

340g

Branding Options:

Embroidery, Vinyl, Screen, Transfer

4 pockets • all zipped • Fixed waist • UPF 40+ sun-protection • Approximately 250g of recycled material went into making this product.



Expert Packable Overtrouser CEW010



800
Black
New



3G3
Dark Navy
New



NEW - EXPERT PACKABLE OVERTROUSER

Fabric Description:

EN343-3 Bluesign-approved AquaDry Membrane polyester 2.5L with EcoShield DWR, recycled polyester trim & recycled zip tapes.

Fabric Composition:

Main: 100% polyamide / Trim: 100% polyester

Sizes:

S/R/L XS - XXL

Fit:

Relaxed

Weight:

90g/m²

Branding Options:

Embroidery, Vinyl, Screen, Transfer

2 pockets • both zipped • Elasticated waist with drawcord • Ankle zips with self fabric zip guard & adjuster
• 90g/m² • Approximately 16 bottles were recycled to make this product.



Expert Merino Half Zip Long Sleeved Baselayer II CEU001



800
Black
New



NEW - EXPERT MERINO HALF ZIP LONG SLEEVED BASELAYER II

Fabric Description:	Merino rich wool & recycled polyester blend. Recycled zip tape.
Fabric Composition:	80% merino, 20% polyester
Sizes:	XS - 3XL
Fit:	Relaxed
Weight:	180g/m2
Branding Options:	Embroidery, Vinyl, Screen, Transfer

28" length • Half-zip with inner zip guard • 180g/m2 • Approximately 7 bottles were recycled to make this product.

Expert Merino Baselayer Tight CEU002



800
Black
New



NEW - EXPERT MERINO BASELAYER TIGHT

Fabric Description:	Merino rich wool & recycled polyester blend.
Fabric Composition:	80% merino, 20% polyester
Sizes:	XS - 3XL
Fit:	Relaxed
Weight:	180g/m ²
Branding Options:	Embroidery, Vinyl, Screen, Transfer

Elasticated waist • 180g/m² • Approximately 6 bottles were recycled to make this product.

Expert Kiwi Sun Hat CEC003



W35
Carbon Grey



EXPERT KIWI SUN HAT

Fabric Description: Polyester cotton with EcoShield DWR finish.
Fabric Composition: Main: 65% polyester, 35% cotton / Trim: 100% polyester
Sizes: S/M, M/L
Weight: 85g

UPF 50+ sun-protection • Approximately 7 bottles were recycled to make this product.

Expert Kiwi Ranger Hat CEC002



W35
Carbon Grey

62A
Pebble

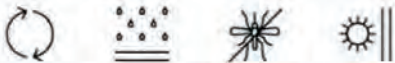

EXPERT KIWI RANGER HAT

Fabric Description:	Polyester cotton with EcoShield DWR finish.
Fabric Composition:	Main: 65% polyester, 35% cotton / Trim: 100% polyester
Sizes:	S/M, M/L
Weight:	115g
Branding Options:	Embroidery, Vinyl, Screen, Transfer

UPF 50+ sun-protection • Approximately 5 bottles were recycled to make this product.



Expert Kiwi Cap CEC004



W35
Carbon Grey
New

62A
Pebble
New



NEW - EXPERT KIWI CAP

Fabric Description:

Polyester cotton with EcoShield DWR finish.

Fabric Composition:

Main: 65% polyester, 35% cotton / Trim: 100% polyester

Sizes:

One Size

Weight:

70g

Branding Options:

Embroidery, Vinyl, Screen, Transfer

Approximately 3 bottles were recycled to make this product.



Expert Trek Sock CEH001



800
Black



EXPERT TREK SOCK

Fabric Description:

Merino blend.

Fabric Composition:

38% Merino wool, 38% polypropylene, 22% polyamide, 2% elastane

Sizes:

6-8, 9-12

Weight:

76g

Expert Kiwi Waist Pack CEX001



800
Black



EXPERT KIWI WAIST PACK

Fabric Description:

Recycled polyester 900D with EcoShield DWR finish & PU backing and recycled zip tape to all zips.

Fabric Composition:

Main: 100% polyester with PU coating / Strap webbing : 100% polyamide

Sizes:

One Size

Weight:

215g

Approximately 3 bottles were recycled to make this product.

Expert Kiwi BackPack 14L CEX002



800
Black



EXPERT KIWI BACKPACK 14L

Fabric Description:

Recycled polyester 900D with EcoShield DWR finish & PU backing and recycled zip tape to side and internal pockets.

Fabric Composition:

Main: 100% polyester with PU coating / Strap webbing : 100% polyamide

Sizes:

One Size

Weight:

440g

Approximately 9 bottles were recycled to make this product.

16L Kiwi Classic Rolltop CEX003



800
Black
New



NEW - 16L KIWI CLASSIC ROLLTOP

Fabric Description:	Recycled Polyester 900D with WR Finish & PU Backing
Fabric Composition:	Main: 100% polyester with PU coating / Strap webbing : 100% polyamide
Sizes:	One Size
Weight:	480g

Approximately 7 bottles were recycled to make this product.

**Card Wallet
CEX004**



800
Black



CARD WALLET

Fabric Description:

Fabric Composition:

Sizes:

Weight:

295g/m²

Recycled polyester 900D with EcoShield DWR finish & PU backing.

100% polyester with PU coating

One Size

295g/m²

Travel Wallet CEX005



800
Black



TRAVEL WALLET

Fabric Description:

Recycled polyester 900D with EcoShield DWR finish, PU backing & recycled zip tape.

Fabric Composition:

100% polyester with PU coating

Sizes:

One Size

Weight:

295g/m²

295g/m²

Neck Pouch CEX006



800
Black



NECK POUCH

Fabric Description: Recycled polyester taslan & recycled zip tapes.
Fabric Composition: 100% polyester
Sizes: One Size
Weight: 80g/m²

80g/m² • Approximately 2 bottles were recycled to make this product.



TECHNOLOGIES

Every season, Craghoppers creates and refines a host of outstanding technologies designed to enhance movement, manage moisture, promote freshness, resist stains, defend against insects, reduce maintenance, provide insulation and protect the wearer from the prevailing weather conditions all year round!

AQUADRY

Guaranteed waterproof and breathable fabric.

Waterproof, breathable, taped seams and water tight constructions. Designed for moderate to heavy downpours.

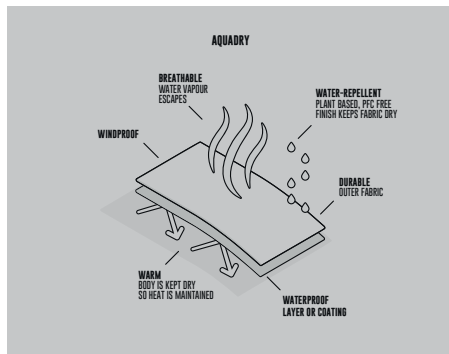

What is AquaDry?

A combination of our waterproof and breathable coating and our technical outer fabrics delivers guaranteed levels of protection and comfort.

The outer face is treated with our EcoShield DWR (Durable Water-repellent) finish to help keep the outer fabric drier for longer. The final product provides guaranteed breathability and all-round waterproof performance.

ECOSHIELD

Naturally water resistant.

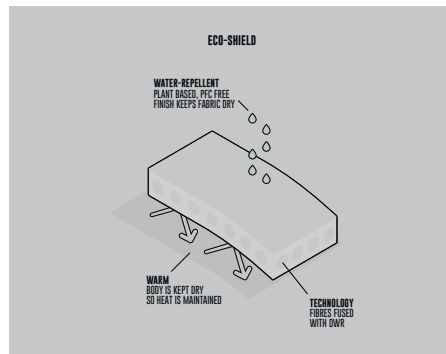

What is EcoShield Technology?

A naturally water-resistant coating, inspired by nature. 63% renewably sourced from a variety of plant-based sources. EcoShield allows fabrics to be quick drying and also repels water based stains.

NOSI DEFENCE

An effective barrier to biting insects.

Keep bugs at arm's length.

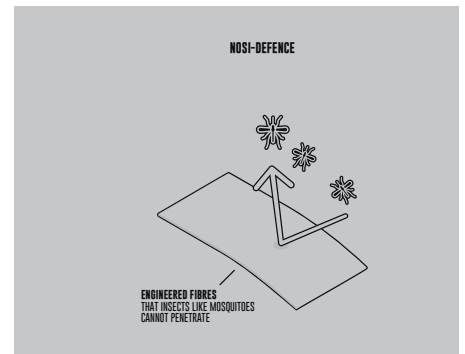

What is NosiDefence?

NosiDefence provides a robust barrier of specially constructed fibres which are too tough for insects like mosquitoes to penetrate.

NosiDefence fabric will help to defend your skin from insect bites allowing you to enjoy your adventures carefree.

THERMO PRO

Innovative high loft insulation.

Stay warm on the trail with high loft down-effect insulation.

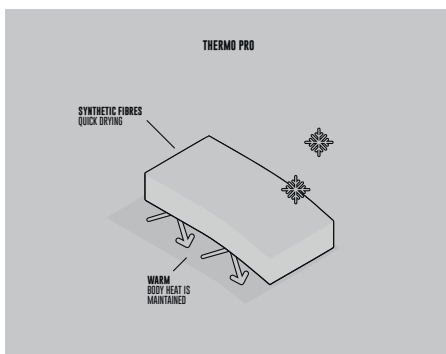

What is ThermoPro?

A new insulating technology that provides a viable synthetic alternative to natural down. The innovative ThermoPro fill uses specially constructed fibres to simulate down construction, delivering comparable heat retention properties.

Light, high loft and quick-drying for effortless efficiency in cold and wet conditions.

SOLAR SHIELD

UPF40+ Sun-protective clothing.

Get out there and enjoy the sun without taking risks. Our SolarShield fabric technology has been tried and tested to give you UPF40+ protection from harmful UV rays.

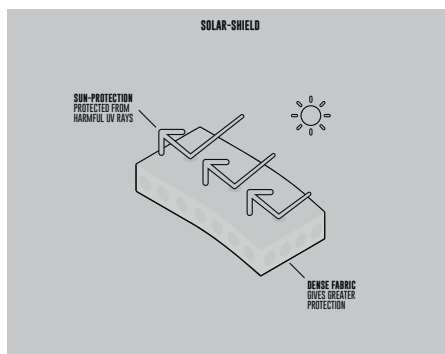

SolarShield is Craghoppers' range of sun-protective fabric tested for UV-protection UPF40+.

Sun-protection is given by a combination of 3 things, the density of the fabric construction, the type of yarns used and its colour.

SolarShield Rating: Excellent
UPF Index: 40+
Blocked UVR: 97.5%+
UV Radiation: 2.5% or less



World leading waterproof and breathable fabrics for all weather conditions.

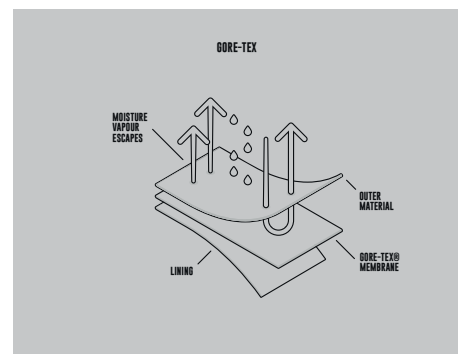

Craghoppers together with Gore, create world leading waterproof and breathable jackets for all weather conditions. Adventurers world-wide have been putting GORE-TEX Products through their paces for years and it still comes out on top as the finest waterproof and breathable fabric there is. Now with a PFC free durable water repellent finish.

SIZING & FIT GUIDE

All our garments are designed specifically for purpose.

The measurement tables and diagrams show how each size and fit differs to help you see which suits you best.

WOMENS	TOPS											Length	Inch
	Size to fit	6	8	10	12	14	16	18	20	22	24		
	Bust (inch)	30	32	34	36	39	41	43	45	47	49	Short	28
	Bust (cm)	76	81	86	91	99	104	109	114	119	124	Regular	31
	US Sizing	XXS/2	XS/4	S/6	M/8	L/10	XL/12	XXL/14	3XL/16	4XL/18	5XL/20	Long	33
	EU Sizing	32	34	36	38	40	42	44	46	48	50		
	FR Sizing	34	36	38	40	42	44	46	48	50	52		

BOTTOMS (EXCLUDING NEW EUROPEAN FIT ITEMS)

Size to fit	6	8	10	12	14	16	18	20	22	24
Waist (inch)	24	26	28	30	33	35	37	39	41	43
Waist (cm)	61	66	71	76	84	89	94	99	104	109
Hip (inch)	33	35	37	39	42	44	46	48	50	52
Hip (cm)	84	89	94	99	107	112	117	122	127	132
US Sizing	XXS/2	XS/4	S/6	M/8	L/10	XL/12	XXL/14	3XL/16	4XL/18	5XL/20
EU Sizing	32	34	36	38	40	42	44	46	48	50
FR Sizing	34	36	38	40	42	44	46	48	50	52

MENS	TOPS									Length	Inch
	Size to fit	XS	S	M	L	XL	XXL	3XL	4XL		
	Chest (inch)	36	38	40	43	46	49	52	55	Short	29
	Chest (cm)	91	97	102	109	117	124	132	140	Regular	31
	US Sizing	36	38	40	43	46	49	52	55	Long	33
	EU Sizing	46	48	50	52-54	56	58	60-62	64	Extra Long	35
	FR Sizing	48	50	52	54-56	58	60	62-64	66		

BOTTOMS

Size to fit	28	30	32	33	34	36	38	40	42	44
Waist (inch)	30	32	34	35	36	38	40	42	44	46
Waist (cm)	76	81	86	89	91	97	102	107	112	117
EU Sizing	42	44	46	48	48-50	52	54	56	58	60
FR Sizing	38	40	42	43	44	46	48	50	52	54

ACCESSORIES	UNISEX	
	Hat size	Head (cm)
	S/M	55-57
	M/L	58-60
	Glove Size	Hand (cm)
	S/M	17-18
	S/M	19-20
	S/M	21-22

SOCKS	UNISEX	
	UK	EU Sizing
	6 - 8	39-42
9 - 12	43-47	

FOOTWEAR SIZING	UK Sizing	3	4	5	6	6.5	7	8	9	9.5	10	11	12	13
	EU Sizing	36	37	38	39	40	41	42	43	44	45	46	47	48

WHAT TO MEASURE

HEAD	The circumference around the middle of your forehead
HAND	The circumference around the palm
BUST/CHEST	Under your arms, around the fullest part of your chest
WAIST	Around your natural waist line at the top of the hips
HIP	Around the fullest part of you body at the top of the leg
LENGTH	From the inside leg to the bottom of your ankle

ACTIVE FIT

Fitted cut with active styling and stretch fabric or detail.

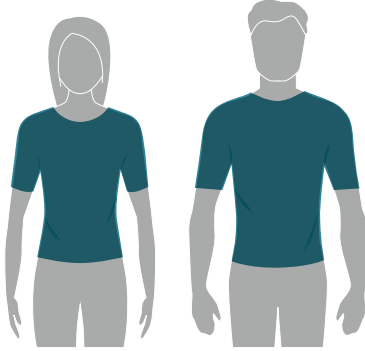

RELAXED FIT

Generous fit for comfort and freedom of movement.

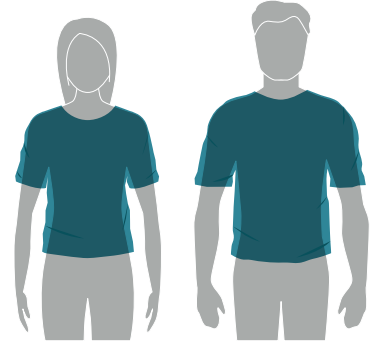

TAILORED FIT

A regular cut slimmer through the chest, waist, hem & sleeve.

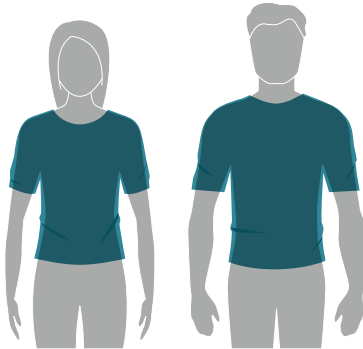

WARMTH RATING

There is a big misconception that heavier means warmer, this is not the case with modern fabrics. Multiple layers trap more air than one single bulky layer and give more flexibility to regulate body heat by adding or removing layers as you heat up or cool down.

Also depending on the garment it may also be wind-resistant or even windproof. This can make a huge difference even if the garment does not have high insulation as being able to cut the windchill can literally be the difference between life and death.

Additionally it is worth remembering that everybody will experience cold differently and what suits one person may not work for another.

Our warmth rating system is designed to explain the insulating properties of our clothing, when worn as part of a technical layering system.



- 3 OPTIMUM**
Optimum insulation for extreme conditions at a temperature range of approximately 0°C/-20°C
- 2 ENHANCED**
Enhanced performance for colder climates at a temperature range of approximately 10°C/-5°C
- 1 REGULAR**
Insulating warmth for every day comfort at a temperature range of approximately 15°C/5°C

WARMTH RATING

There is a big misconception that heavier means warmer, this is not the case with modern fabrics.

Multiple layers trap more air than one single bulky layer and give more flexibility to regulate body heat by adding or removing layers as you heat up or cool down.

It is worth remembering that everybody will experience cold differently and dependent on activity and exposure time, what suits one person may not work for another.

BELOW INDICATES OUR RATING FOR THIS PRODUCT:







CRAGHOPPERS

EXPERT

